

RADIANT CATALYTIC HEATERS CAT-RAY® TYPE 10 and 3

Technical specifications
and features







Contents

1.	Technical description of the appliance	4
2.	Technical specifications.....	6
3.	Catalytic combustion.....	8
4.	Operating conditions for the apparatus ¹	10
4.1.	Nominal power	10
4.2.	Getting the apparatus into function.....	11
4.3.	To stop the apparatus.....	11
4.4.	Apparatus goes on failure	11
5.	Regulation of the RADIAMON apparatus	11
6.	Heating power to install	12
7.	CO ₂ and H ₂ O concentrations as a function of the air renewal rate	13
8.	Calculation of the heating requirements of a building.....	14
9.	Fuel consumption of a RADIAMON system	15



1. Technical description of the appliance

In figure 1 (page 4) you can see a transversal cut of the apparatus (for instance the CAT RAY © N/P).

In the upper part the air is aspired from the environment by a ventilator before « pushed » equally to the inner borders of the apparatus. The air is consequently blown equally on the surface of the panel towards the center.

Electrically heated spirals which are incorporated in the catalyst are heated up for creating a certain temperature.

Once the required temperature is reached the gas is flowing through one or two valves (security, regulation) and conducted to the catalyst. The gas flows equally through the fibres (covered with Platin) which are the support (catalyst) for the catalytical combustion. The temperature gives the ignition for the combustion. The electricity for the electrically heated spirals is turned off and the apparatus is on i.e. a flameless combustion. The air support is giving the necessary quality combustion.

Through this invention/process the combustion is relatively slow compared to traditional combustion. There for a complete combustion is obtained with indefinite quantities of CO (carbon monoxide) at temperatures around 300 to 700°C. The surface temperature is less than 400°C. The low temperature level permits to work NOx free (nitrogen oxides). There is very little impact on the environment.

The apparatus is based on a modular construction. The upper part is a support for the parts related to the control of the functions, electrical/electronic parts and the guidance of the gas. The lower part is the panel i.e. catalyst. The parts can be separated by opening the clips on the side of the panel. This permits the fast change of the panel on site. Duration of the panel is between 8000-14'000 hours depending on the air hygiene of the working environment.

Note: Chlorine and sulphate in the air are destroying the catalyst

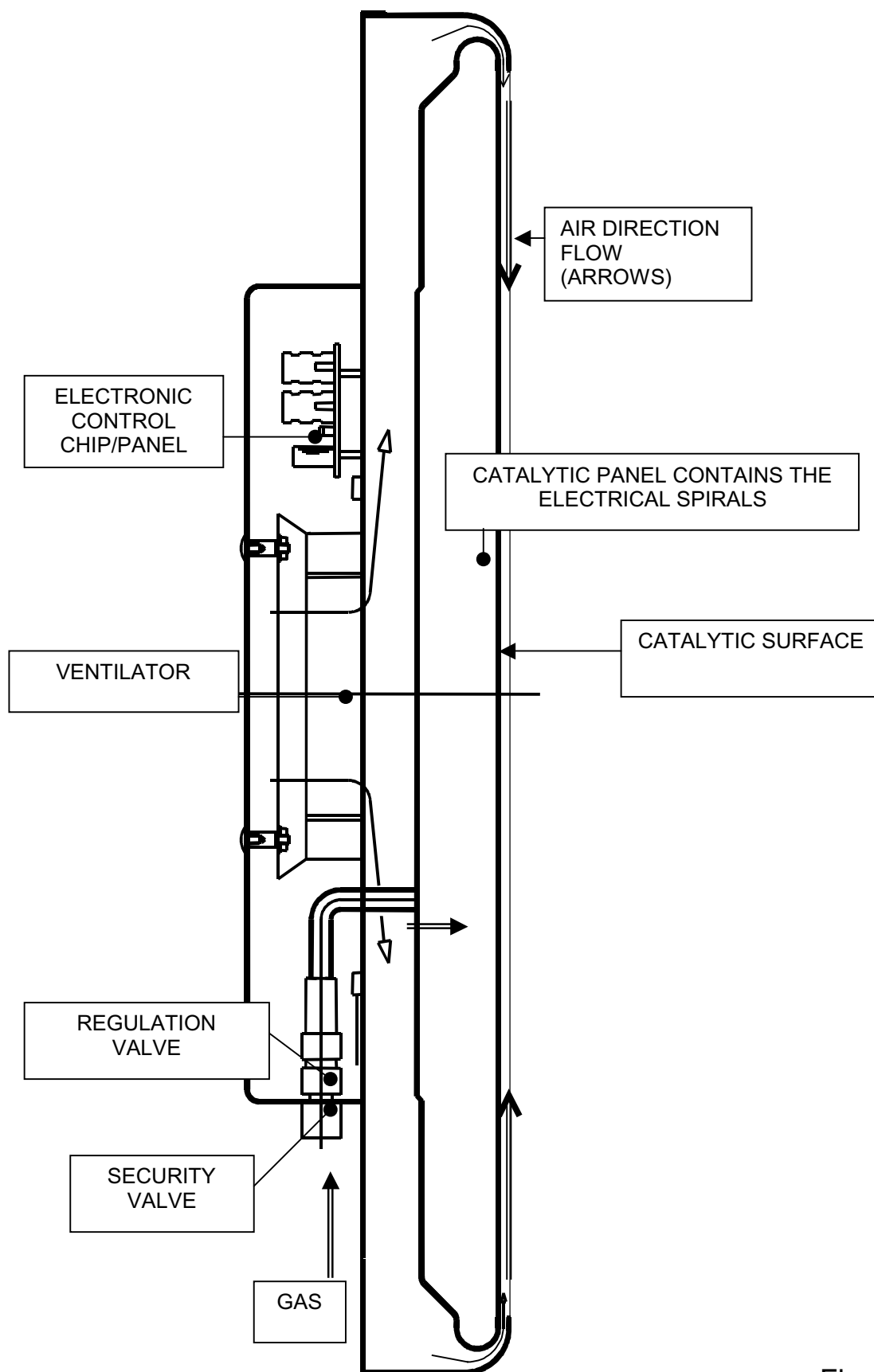

Figure 1



2. Technical specifications

Model CAT-RAY 10 RADIAMON appliance

Type of gas	Natural gas	Propane
Effective power (kW)	9.5	9.5
Radiated power (kW)	4.7	4.7
Gas flow:		
GNH (Lacq)(m ³ per hour)	0.99	-
GNL (Gronigen)(m ³ per hour)	1.17	-
Propane (kg per hour)	-	0.75
Air consumption for combustion (m ³ per hour)	9	10
Electric power:		
- for start-up (W)	120	120
- when heating (W)	30	30

Model CAT-RAY 3 RADIAMON appliance

Effective power (kW)	3	3
Radiated power (kW)	1.5	1.5
Gas flow:		
GNH (Lacq)(m ³ per hour)	0.31	
GNL (Gronigen)(m ³ per hour)	0.37	
Propane (kg per hour)		0.24
Air consumption for combustion (m ³ per hour)	2.85	3.15
Electric power:		
- for start-up (W)	120	120
- when heating (W)	30	30

Gas characteristics

	Pressure	lower calorific value
GNL (Gronigen)	25 mbar	8.1 kWh/m ³
GNH (Lacq)	20 mbar	9.25 kWh/m ³
Propane	37 mbar / 50 mbar ⁽¹⁾	12.8 kWh/kg

⁽¹⁾ According to pressure applicable in each country



Dimensions: Appliance CAT-RAY 10 weight: 10 kg

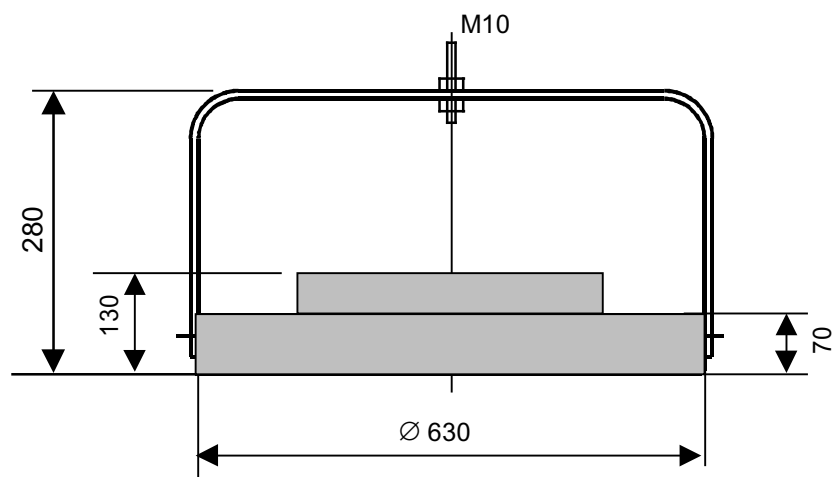

Dimensions: Appliance CAT-RAY 3 weight: 9.5 kg

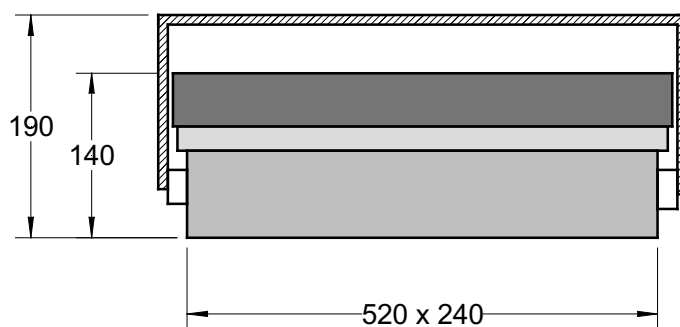



3. Catalytic combustion

A catalyst is a substance that accelerates a chemical process without being consumed during that process (or insignificantly)

A catalyst has the effect to improve a chemical reaction without modification of the thermodynamic equilibrium. The quantity of energy (heat) created by this process is the same with or without catalyst. Ultimately the role of the catalyst is to accelerate the process in order to reach faster the thermodynamic equilibrium.

The catalyst

generally speaking, a catalytical system consists of:

- a porous support which has on one hand to define the biggest possible specific surface because the chemical reaction is happening on the interface between the solid mass and the gaseous fluid. On the other hand it has to avoid that the stabilising element (Platinum in this case) which initially is dispersed equally on the catalyst fibres is “grilled” ie is getting concentrated in a part of the catalyst because of an excess of heat. Such a “concentration” creates a loss of surface and therefore a loss of efficiency of the catalyst;
- of an active phase – generally speaking metal in transition or oxide (the most used today is Platinum) – which gives the active parts (parts on which the chemical reactions happen)
- of one or several promoters which have as a role to stimulate the activity, to avoid the “grilling” of the active phase and the poisoning of the catalyst.

The efficiency of the catalyst depends on the quality of the components and its application. There are a number of factors to take into consideration during production and the control of the parameters are the necessary know how.

Advantages of the catalytic combustion

The catalytic combustion has as its main advantages the facts that it doesn't produce NO_x (nitrogen oxides) and no CO (carbon monoxide). This advantage is even more valuable if one thinks about the drastic measures government is imposing for reducing environment pollutants.

The fact that the system works flameless is another strong point. In fact it allows the utilisation on/in places which are fire (or explosion) sensitive. Solvents and hydrocarbons are transformed into oxides like gas. Unfortunately the RADIAMON Apparatus has not been submitted for to be used in EX zones.





4. Operating conditions for the apparatus ¹

4.1. Nominal power

Nominal power

The radiant catalytical panels have a nominal power of 9,5 kW which the gas pressure shown in the board below

The CAT-RAY © 10 has two power levels on which it functions (regulated by an electro valve). The CAT-RAY© 3 N/P functions on one power level only.

(a)

Pressure mbar		AT	BE	DK	DE	CH	FR	GB	NL	SE
50	P	X			X				X	
30	P								X	
37	P		X			X	X	X		
29	PB									
25	GN		X				X		X	
20	GN	X	X	X	X	X	X	X		X
P=Propane ; GN=Natural gas ; PB= Propane/Butane										

(b) The diaphragm type has to correspond with the used gas

HL = natural gas
P_{37/50} = propane

! Never run an apparatus prepared for a diaphragm HL(natural gas) with propane.

¹ We reserve the right to make any changes required for the purpose of improvement.



4.2. Getting the apparatus into function

To make the apparatus functioning simply open the gas valve (Propane or natural gas) and turn on the electric switch (regulation manually or temp. control panel)

All the rest works automatically because of the integrated control panel system

A pre-ventilation of 2 minutes is happening before the apparatus starts the catalyst surface is preheated with the help of the incorporated electric spirals as soon as the necessary temperature on the surface of the catalyst is reached the electric controlled valves (security and regulation) are opening and the gas starts flowing. An automatic temperature control is happening 2 minutes after the security valve has opened in order to check if the apparatus is functioning. The catalytic process is getting into place and produces the necessary heat for a complete surface combustion.

The electricity feeding the pre-electric spirals is cut off two(2) minutes after the opening of the security valve.

Parallel to this steps the ventilator is working from the beginning.

Latest 10 minutes after the opening of the security valve the regulation valve is opening. It opens and closes according to the impulses received from the temp. control panel or manual impulse.. The system is fully operational.

4.3. To stop the apparatus

The apparatus stops automatically either due to a programmed stop (as soon as a certain temp. is reached in the heating area) or a manual stop or by a security function. The electric security valve closes and the ventilator stops.

4.4. Apparatus goes on failure ...

The apparatus has a two-coloured Diode. The different colours indicates the functioning modus ie :

* Diode blinking (green)	it's in the start-up phase
* Diode green	In function
* Diode red (blinking)	Problem/failure
* Diode red (continued)	Indicates that the apparatus has more than 5000 hours of functioning. No failure

5. Regulation of the RADIAMON apparatus

- A. Through an "interrupter" electric or a switch 0-I-II (3 positions) for the CAT RAY ©10 N/P
- B. Through an "interrupter" electric or a switch 0-I (3 positions) for the CAT RAY © 3 N/P



- C. Through a regulation board/panel (please contact the supplier of the board/panel for more information)
- D. through the electronic chip in each apparatus which controls and conducts fully autonomic the start-up and security.

6. Heating power to install

The heating power to be installed in a building is determined on the basis of its heat losses (that is to say, heat loss by conduction through the outer walls and by convection through air exchange). Account is to be taken of the maximum difference between the desired indoor temperature and the outdoor temperature. On page 12, a calculation example for a realized heating system is given for illustration.

The total energy released by gas combustion (natural gas or propane) is used to heat the building, either in the form of radiative and convective heat. The uniform heating of the air within the building and the absence of any stratification of air makes additional loss due to local overheating virtually negligible.

Convective heat equalizes efficiently the temperature within the building, so that the exact distribution of radiative heat over the floor becomes of secondary importance.

Air renewal rate

The air renewal of the building, whether natural (by opening doors and windows or the permeability of the building envelope) or forced, dilutes the combustion gases released by the heating system, thus maintaining the carbon dioxide and humidity contents below given, prescribed levels. The concentration of these combustion gases is shown in the attached diagram (Figure on page 11) as a function of the dilution factor. As a general rule, the mean air renewal has to be at least 20 times higher* than the quantity of air needed for the combustion process¹. This dilution will reduce the CO₂ content of the atmosphere to less than 0.5% = 5000 ppm (0.6% = 6000 ppm using propane).

At the same time, the air humidity is slightly increased (by 0.6% with natural gas or 0.5% with propane) over that of the air outside the building which, in Winter makes the atmosphere all the more pleasant.

In most cases, the natural air renewal rate of the building will be found to be sufficient to provide good air quality in the areas heated by the RADIAMON system

In Winter, the air renewal should in no case be more than 50 times the volume of air required for combustion, since otherwise the heat loss by ventilation will be greater than the heating energy needs of the building.

* to refer to the standards in force in the country. Example : 10 x (European standard EN 13410:1999)

¹ This minimal required air renewal rate will in general be lower than the air renewal rate normally accepted for hygienic reasons.



7. CO₂ and H₂O concentrations as a function of the air renewal rate

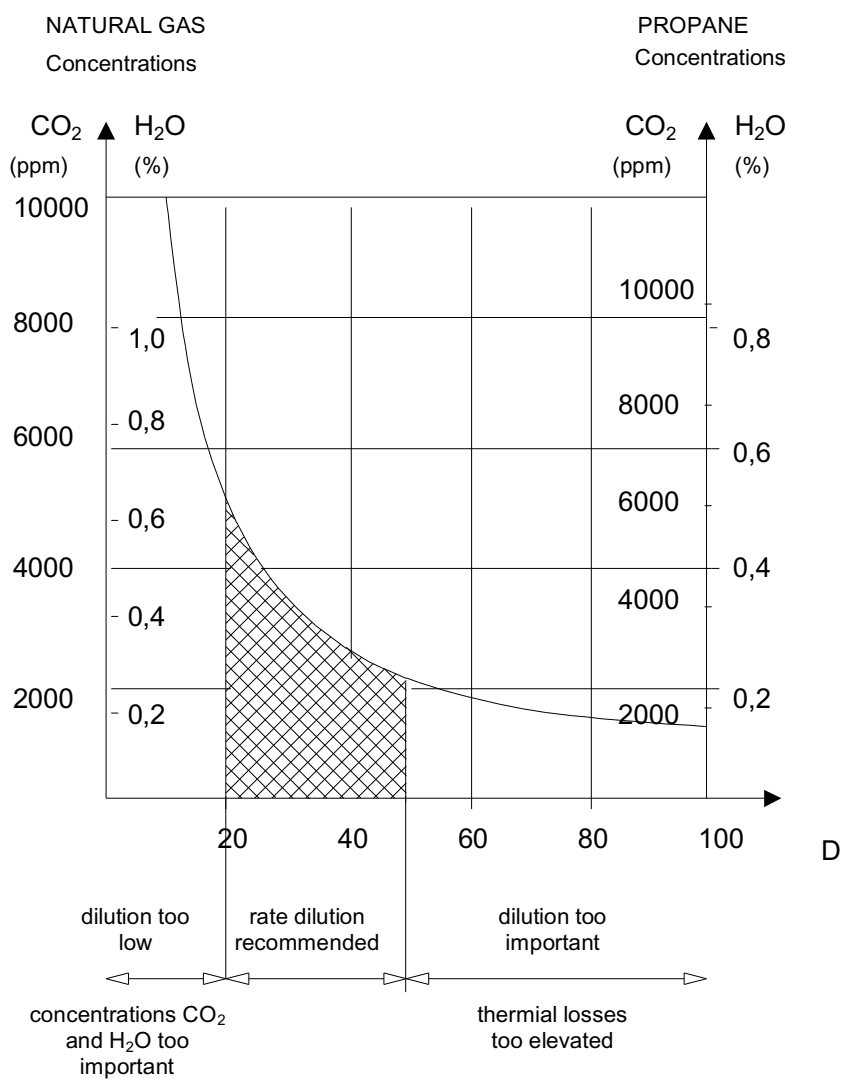

$$D = \frac{\text{air renewal rate}}{\text{combustion air rate}}$$

Figure 2



8. Calculation of the heating requirements of a building Example of a realized heating system

Layout of a RADIAMON heating system for an exhibition hall

Size of hall: 43 m x 46 m = 1978 m²

Volume to be heated: 1978m² x 5 m = 9890 m³

External walls: perimeter = 178 m
total surface = 890 m²

of which doors 6 x 3m x 4m = 72 m²
windows = 252 m²
façades = 566 m²

<u>Heat loss by conduction:</u>	Surface (m ²)	k (W/m ² °C)	(W/°C)
Doors	72	5.0	360
Windows	252	2.5	630
Façades	566	0.4	226
Roof	1978	0.6	1187
Floor	1978	0.35	692
	<u>4846 m²</u>		<u>3095 W/°C</u>

Loss by heat conduction:

- For $\Delta T = 25^{\circ}\text{C}$ $Q_{\text{cond}} = 77.4 \text{ kW}$

Loss by air renewal:

- Air renewal = 0.3 vol per hour $V = 2967 \text{ m}^3$ per hour
- For $\Delta T = 25^{\circ}\text{C}$ $Q_{\text{cond}} = 24.7 \text{ kW}$

Nominal heating power requirements:

(Taking no account of additional internal heat sources such as machines, persons, etc.)

- Q tot = 102.1 kW
- Q install = 114 kW

FOR HEATING THE EXHIBITION HALL :

Proposal: 12 appliances of CAT-RAY 10 to be installed.



9. Fuel consumption of a RADIAMON system

Example of a realized heating system

By way of example, the heating system of the Planchy factory belonging to Bernard Sottas SA of Bulle in Switzerland is presented. These industrial premises, where metal roofing frames are made, were built in 1988 alongside the Vevey-Fribourg motorway at an altitude of 770m and is now equipped with a RADIAMON heating system. Since it was installed, it operates reliably and has given full satisfaction both in terms of costs and staff comfort.

Data for the heat study

- Type of building: well insulated and water-tight industrial hall.
- Ground area: 5'070 m²
- Volume: 57'000 m³
- Temperatures:
 - during working hours: +15°C (air temperature)
 - equivalent to: +18°C (comfort temperature)
 - outside working hours: + 5°C (minimum)
- Air renewal rate 0.5 times building volume per hour
- Fuel: propane, 11'000 kcal/kg (lower calorific value)

RADIAMON system

- Calculated heat loss: 609 kW (coldest day)
- Internal heat sources: 36 kW
- Recommended thermal power using the RADIAMON system: 627 kW
- Installed thermal power: 627 kW, i.e. 66 RADIAMON CAT-RAY 10 -propane appliances
- Fuel consumption at full power: ~50 kg propane per hour

Effective consumption of the RADIAMON system

- Winter 1988/1989: 28'179 kg at CHF 0.538 per kg = CHF 15'160.-
- Annual cost per m³: 26.5 centimes
- Annual cost per m²: CHF 3.-
- Winter 1989/1990: 20'812 kg at CHF 0.590 per kg = CHF 12'279.-
- Annual cost per m³: 21.5 centimes
- Annual cost per m²: CHF 2.42



Drawings representing the modulation of the appliance CAT-RAY 10

